

MoviChip

MAF Manager 2.0



WARNING

MoviChip products should be used for motorsport and/or off-highway use **only**.

MoviChip products should **only** be installed & adjusted by persons who are experienced with automotive electrical and mechanical systems and the effects of altering such systems.

MoviChip products can **radically** alter and potentially interfere with the performance of vehicle systems. Misuse or improper tuning of MoviChip products can cause unexpected vehicle behaviour and/or failure (temporary or permanent) of existing vehicle systems eg limp mode, engine damage etc.

MoviChip products are **universal**. It is the responsibility of the end user to ensure MoviChip products are compatible and suitable for their specific application. MoviChip is not responsible for special, incidental or consequential damages or costs incurred due to the failure of this product.

MoviChip products are used **entirely** at the risk of the end user.

MOVICHIP ©2018

Thank you for choosing MoviChip

MAF Manager.....	3
1. Overview.....	3
2. Wiring.....	3
2.1. Bare Connector.....	3
2.2. Pre Populated Connector.....	4
3. Set Up.....	4
3.1. Bluetooth.....	4
3.2. Settings - Basic.....	5
3.2.1. Load Points.....	5
3.2.2. SET Menu - Multiplier Settings.....	5
4. MAF Manager Settings – Advanced (Optional).....	5
4.1. CAL Menu.....	5
4.2. MAF Menu Settings.....	6
4.2.1. MAF Lock.....	6
4.2.2. MAX Volt.....	6
4.2.3. Clamp Voltage IDLE.....	6
4.2.4. Gear Stabilisation.....	7
4.3. MAF Menu Sensor Readings.....	7
5. SET Menu - X High Load Multiplier.....	7
6. App Options.....	7
6.1. Button Response.....	7
6.2. Guide.....	8
6.3. Colours.....	8
7. Using the App.....	8
8. FAQ.....	8
8.1. Engine is jerky, what is the problem?.....	8
8.2. I want to use the MAX Volt clamp feature but not the idle or gear stabilisation function is it possible?.....	8
8.3. The AFR on my gauge does not match the AFR shown on the MAF Manager App, what can I do?.....	8
8.4. I have running problems with my engine, I think it's the MAF, can the MAF Manager help? 8	
8.5. Do I need to wire the MAF Manager into the cars ECU?.....	8
8.6. Where should I mount the MAF Manager?.....	9
8.7. Can I use a different sensor instead of MAP?.....	9

MAF Manager

Overview

The MAF Manager allows the user to alter the MAF signal at according to three load points as read from a 5 volt sensor input.

An example.

The MAF signal is altered **+5%** when the load sensor (MAP/MAF/TPS, we recommend MAP or MAF) is above 75% of it's total range, and by **+6%** between 25% and 75% of the load sensor range and **-3%** below 25% of the load sensor's range.

The MAF Manager is designed to work with MAF sensors which output a voltage of 0-5Volts. MAF Manager does not work with frequency based MAF sensors.

The MAF Manager is designed for fine tuning. It is not suitable for engines which have had major changes eg turbo conversion.

Wiring

The separate connector with the purple slider is numbered across the top with letters down the side. *See image.*



The table below mirrors the layout of the connector.

Bare Connector







If you have purchased a bare connector, populate the connector with your wires as shown in the table below. Colour of wire used for each terminal is entirely up to you.

Pre Populated Connector

If you have purchased a premade loom, trace the wires back to their connector location to determine their purpose. The colour of the wires is **irrelevant**. The colour of the wires does **not** identify the purpose of that specific wire.

MAF Manager2 Pinout

MAF MANAGER	8	7	6	5	4	3	2	1
A			MAF SIGNAL IN	LAMBDA SIGNAL IN	MAP SIGNAL IN		SENSOR 1 Power POS 5V	SENSOR 1 GROUND
B				SENSOR2 POWER +	MAF OUT - To car ECU			IGNITION 12V +
C				SENSOR 2 GROUND				BATT Neg 12V -

COLOUR KEY (NOTE: WIRE COLOURS IRRELEVANT)	
	INTERCEPT
	TAP. IF USING MAF AS LOAD SIGNAL TAP BEFORE INTERCEPT
	TAP TO SENSOR GROUND EVEN IF +POWER SUPPLY NOT USED
	ADD INLINE FUSE 1 AMP
	OPTIONAL. USE IF REQUIRED. 0.5AMP CURRENT DRAW MAX
	OPTIONAL

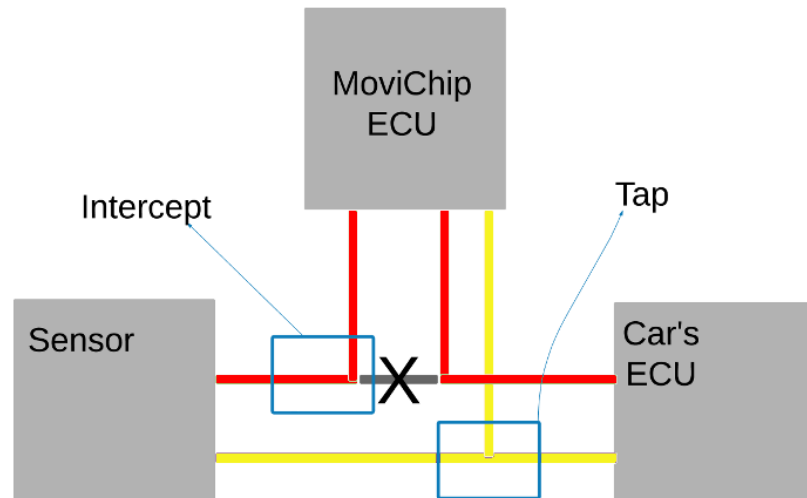

Set Up

Bluetooth

IMPORTANT: When Bluetooth is connected it will delay the response time of the MAF Manager & MAF Sensor signal. Only open menus in the app when vehicle is stationary.

Connecting to the unit to your Android device. With the MAF Manager turned on i.e. with the vehicle in the ignition on position, open the setting menu on your Android device (not

the MAF Manager), go to Bluetooth, turn Bluetooth on, when MAF Manager appears, pair your device. Password 1234.

Only then open the MAF Manager app, press the Bluetooth image and connect your Android device with the MAF Manager.

Check that the wiring is correct by opening the MAF menu and see that the sensors are sending data to the app. Do the same in the MAP menu. Do the same in the CAL menu if you have connected a wideband lambda sensor.



Bar turns green when Bluetooth is connected

Settings - Basic

Load Points

The first step in setting up the MAF Manager is to set your loads points. You can alter the MAF against any sensor input you wish but we recommend using a MAP sensor signal or the MAF sensor signal itself.

To do this we go to the “MAP” menu in the App. Choose the “SPLIT” points you want to use as the dividing point between the difference correction settings. We have Idle-Med and Med-High.

To give an example. If we set Idle-Med to 20% and Med-High to 60%

Whenever the load sensor signal is less than 20% of it's range the MAF Manager will use the “Idle Multiplier” setting.

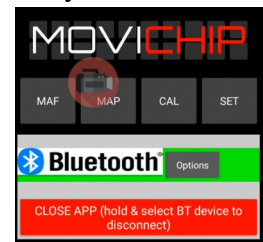

If the load signal is over 20% and less than 60%, the MAF Manager will use the “Low Load Multiplier”.

Over 60% the “High Load Multiplier”.

The setting of the load points is very important. You will probably need to experiment with the “Split” points.

SET Menu - Multiplier Settings

When we have entered or load points, close the MAP menu and open the SET menu. Entirely up to you what you enter here, it will depend on your engine and its modifications. If for an example, you have fitted 20% bigger injectors, setting the multipliers to 0.8 could be a good starting point.

MAF Manager Settings – Advanced (Optional)

CAL Menu.

If you have connected a wideband lambda sensor to the MAF Manager.

In the CAL menu you will see the same load points ie Idle, Low and High Load. By pressing the plus and minus buttons you can use the AFR targets you want for these load points.

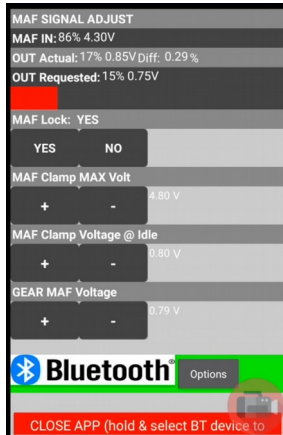

The MAF Manager has been designed to be used with Innovate Motorsport products but if you find the AFR numbers in the app do not correspond precisely with your lambda gauge or if you are using a different brand of lambda sensor and the AFR reading in the app is off use the linear regression formula for your gauge.

Turn the auto tune function on and off by pressing "Use Lambda" "Yes" or "No". If no wideband lambda sensor is connected set the "Use Lambda" option to "No"

NOTE: If the setting is set to "Yes" **on startup**, the auto tune function will start after the ignition has been on for **5 minutes**. If you switch the setting from "No" to "Yes" while the ignition is on, the unit will start auto tuning **immediately**. You do **not** want the auto tune function to start if the engine is **not** up to normal operating temperature.

In normal use, with the "Use Lambda" setting on "Yes", when you turn on the ignition the multipliers in the SET menu will be used for the first 5 minutes.

When you are happy with the targets, close the menu and go for a session with the auto tune active and at the end of the session, with the ignition still on, reopen the CAL menu and see how the multipliers in this menu compare with the multipliers in the SET menu.

They should be close, within 1 or 2 percentage points e.g. if SET menu is 0.8, CAL multiplier should be 0.81, 0.82, 0.78, 0.79, somewhere close, if not identical.

If there is a big difference, alter your multipliers in the SET menu to match the numbers in the CAL menu.

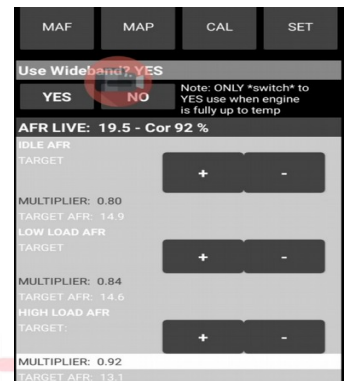

MAF Menu Settings

MAF Lock.

We can set maximum and minimum limits on the MAF signal voltage we can send to the car's ECU. This is entirely optional.

MAX Volt.

With the MAF Lock set to "Yes" the number in the MAX Volt setting will be the highest voltage the MAF Manager will send to the car's ECU.

If you want to set this number to 5 volts you do **not** need the MAF lock function. The MAF Manager can not send more than 5 volts to the car's ECU.

Clamp Voltage IDLE.

Here we can set the minimum voltage the MAF Manager will send to the car's ECU under idle conditions.

We need to tell the MAF Manager *what* is an idle condition.

Open the MAP menu and set the percentage here. This number should be slightly less than the lowest sensor reading you ever get an idle. When the load number drops below the threshold **and** the MAF sensor signal drops below the clamped Idle MAF voltage setting, the MAF lock idle voltage will be sent to the car's ECU.

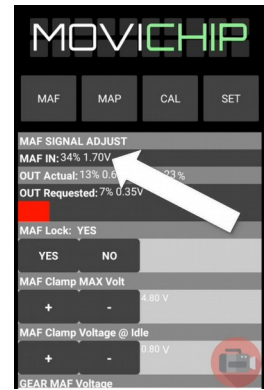

This function is entirely optional and on a normally operating engine there should be no need to use it. This option should not be used if you are also using the auto tune function.

Gear Stabilisation.

This is set in the same way as the Idle MAF clamp except the load level will be set at an even lower load than idle. Choose the load threshold in the MAP menu and set the voltage in the MAF menu. To deactivate, set MAP Gear threshold to lowest possible setting eg 0.5%/1%

Again, this is an entirely optional setting, it should not be used on a normally operating engine.

You can set the idle & gear stabilisation load points where you wish but if you need to output a fixed voltage instead of using the MAF sensor signal, this points to a problem with the set up of the MAF sensor or with the MAF sensor itself. We have included these functions for completeness but we do not recommend using them.

MAF Menu Sensor Readings

At the top of the MAF menu we have three figures. MAF In, Out Requested and Out Actual. These are for diagnostic purposes only. NOTE: Depending on the generation of product you have, "Out Actual" maybe in use, it maybe not, either way it will not affect the performance of the product.

SET Menu - X High Load Multiplier

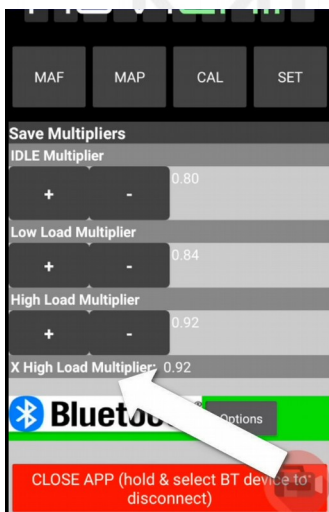

This is an auxiliary multiplier which *may* be used with the auto tune function, if the auto tune function deems it necessary. If, after a session this multiplier is different from the high load multiplier it suggests your MAF sensor is going out of range. If your MAF sensor is going out of range you should change to a MAF sensor that can measure the full range of air flow through the engine.

The MAF Manager CANNOT compensate for a MAF sensor that has gone out of range

App Options

At the bottom of the page in the app there is a button marker “Options”

Button Response

If you want to try and reduce the delay between pressing a button on the app and the numbers changing you can try a different clock speed.

The default number here is 50 and that is what we recommend.

It is normal for there to be a delay between pressing buttons on the app and the numbers updating/menu opening closing.

Data is sent to the MAF Manager unit **from** your Android device and then it is sent **back** to confirm the changes have been received. There is a delay in this process, **it is normal**.

Guide.

This button gives the URL of the product page on the website.

Colours

You can change the colours of the indication bars in the MAF and MAP menus and the logo colour.

Using the App

When driving the app should be closed. If you have the app open and a menu open there will be a delay in the response of the MAF Manager which can lead to jerky movements from the engine. The App should be used only for adjusting the settings it should **not** be used during driving unless for diagnostic purposes.

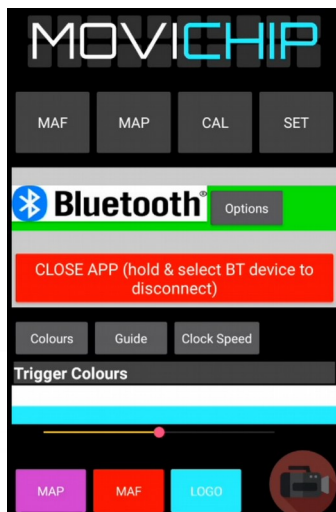

FAQ

Engine is jerky, what is the problem?

Disconnect the app from the MAF Manager unit **correctly**. If not disconnected correctly, turn off ignition, wait 10 seconds and turn on again. If the MAF Manager is sending data to your Android device

it will delay its response. App should **not** be open when driving except for diagnostic purposes. Product will work with a delay when Bluetooth is connected.

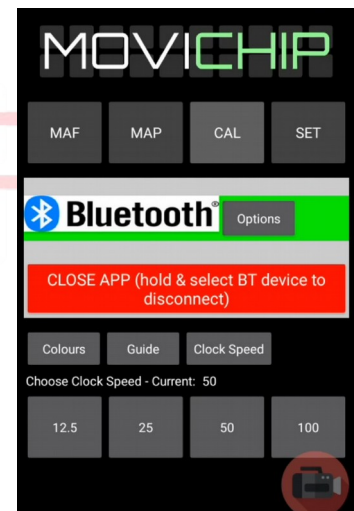

I want to use the MAX Volt clamp feature but not the idle or gear stabilisation function is it possible?

Yes, set the trigger threshold of Idle and Gear Stabilisation to 1% in the MAP menu.

The AFR on my gauge does not match the AFR shown on the MAF Manager App, what can I do?

Product is designed for use with Innovate Motorsports products. If you are using an Innovate product and the AFRs do not match up exactly or you are using a lambda sensor from a different manufacturer, use the liner regression formula for your gauge and enter the details into the app.

I have running problems with my engine, I think it's the MAF, can the MAF Manager help?

The MAF Manager should be used on engine that is running normally ie engine without obvious problems. The MAF Manager is designed for fine tuning, it is not a band aid for a fundamental problem.

Do I need to wire the MAF Manager into the cars ECU?

Yes. Follow the wiring pin out diagram at the top of this page.

Where should I mount the MAF Manager?

The MAF Manager is designed to be mounted in the engine bay away from excess heat and away from sources of water. It should not get wet or hot/cold.

Can I use a different sensor instead of MAP?

You can use any 0-5v sensor you wish but we recommend a MAP or a MAF signal. Note: Using a MAF may make it impossible to use the MAF clamp function, specifically Idle and Gear stabilisation.

MOVICHIP ©2018